

High Spec Dual Raw Sewage Pump Station

A high quality Glass Reinforced Plastic tank complete with guide rail mounted pumps and an autochangeover, duty/standby float control system with built in high level alarm.

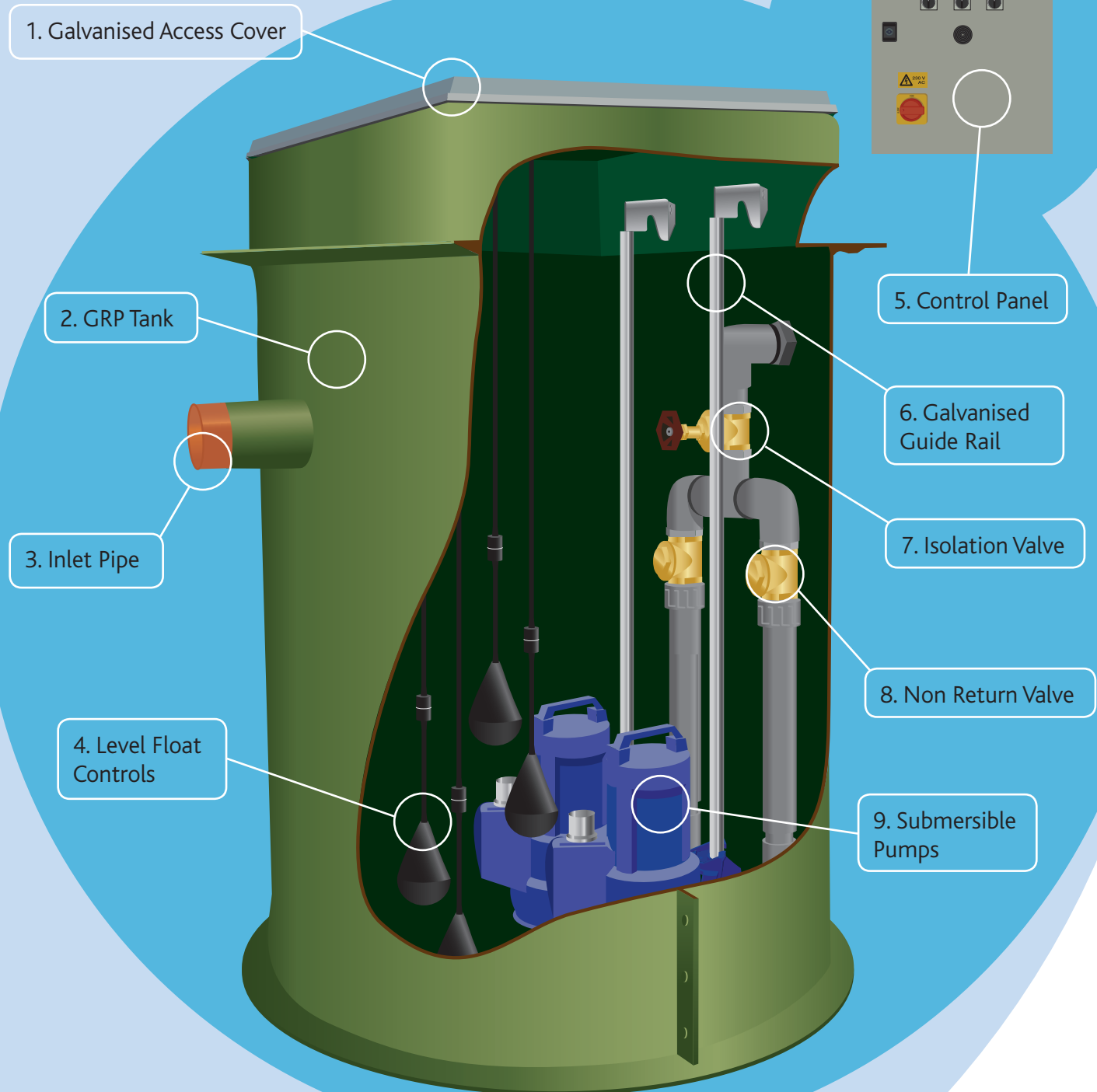

High Spec Dual Raw Sewage Pump Station



How it works

As the level of the liquid rises in the chamber the first two level floats, the stop and duty start floats are activated and the duty pump starts and pumps the liquid out of the chamber until the stop float drops and turns the pump off. The level of the liquid will again rise and due to the autochangeover control system the other pump will start. This ensures that the two pumps do an equal amount of work.

If the liquid level reaches the height of the second level float and the pump fails to pump, the level of liquid will continue to rise until the third float is activated and calls the standby pump to start. This pump will then start and pump until the stop float drops. If both pumps fail to pump, the liquid level will rise to the fourth float and the high level alarm will be activated.

Features & Benefits

- ✓ Pump chambers are manufactured from high quality Glass Reinforced Plastic and in accordance with our BS EN ISO9001:2000 quality management system.
- ✓ Fully automatic autochangeover control system to ensure equal wear and tear on each pump.
- ✓ Pump stations are delivered complete with the pipework, valves and guide rails pre-assembled in the tank, ready for immediate installation into the ground.
- ✓ Wide range of diameters and depths of tanks available to satisfy the storage requirements in part H of the Building Regs.
- ✓ Low maintenance costs, servicing once a year.
- ✓ Custom made units available upon request.
- ✓ Servicing, Installation and Commissioning service available by our highly trained engineers.

Dimensions (mm)

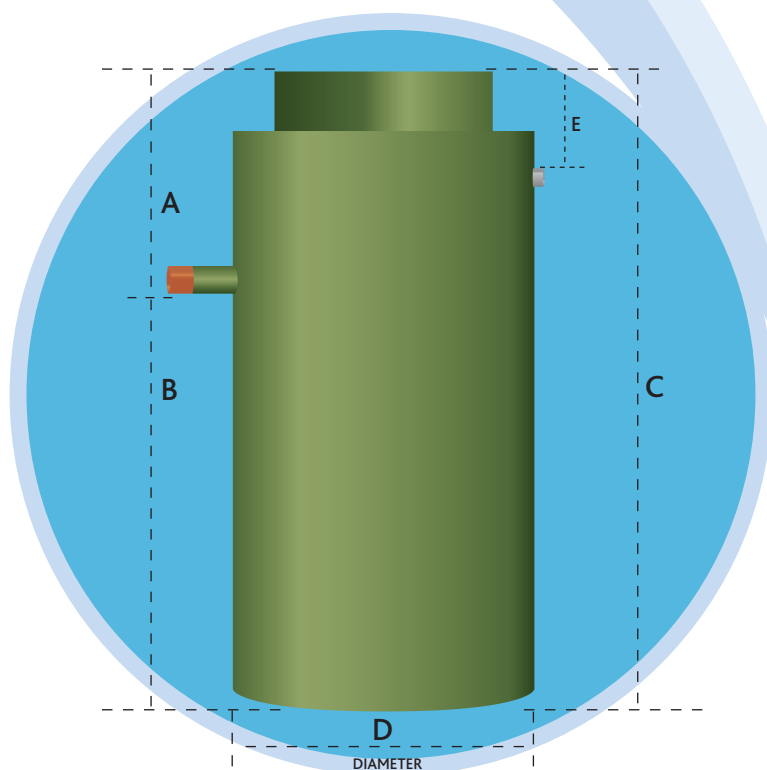

STORAGE CAPACITY / P/E	0	5	12	20	27	44
(A) INLET	500	1000	1000	500	1000	500
(B) BELOW INLET	900	1400	2500	3000	2000	3000
(C) HEIGHT	1400	2400	3000	3500	3000	3500
(D) DIAMETER	1000	1000	1200	1200	1800	1800
(E) OUTLET	350	350	350	350	350	350

Allerton® reserves the right to alter the specifications and dimensions without notice.

**1 YEAR WARRANTY ON
ALL WORKING PARTS**

**FOR FURTHER INFORMATION
CALL: 01529 305757
EMAIL: sales@allertonuk.com**