

# Single Dirty Water Pump Station

A high quality Glass Reinforced Plastic tank complete with single pump and built in high level alarm, ideal for pumping treated effluent from septic tanks or treatment plants for single dwellings.

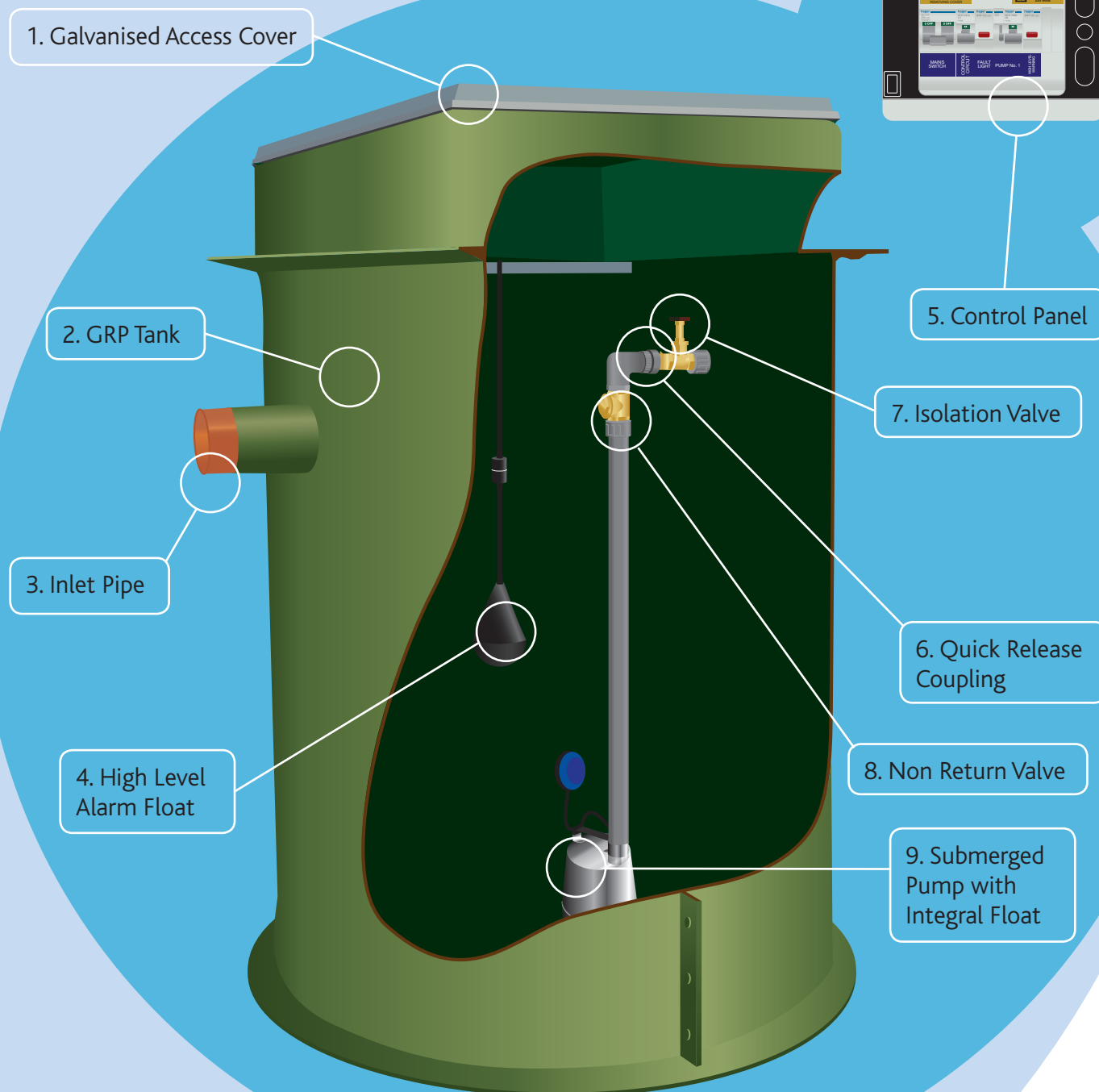

# Single Dirty Water Pump Station



## How it works

As the level of the liquid rises in the chamber the integral float on the pump is activated, the pump starts and pumps the liquid out of the chamber until the pump float drops and the pump turns off.

The level of the liquid will again rise and the above sequence is repeated.

If the pump fails to pump, the liquid level will rise to activate the high level float and the high level alarm light will be illuminated.

For applications involving more than one dwelling we would recommend our dual dirty water pump station.

## Features & Benefits

- ✓ Pump chambers are manufactured from high quality Glass Reinforced Plastic and in accordance with our BS EN ISO9001:2000 quality management system.
- ✓ Single phase and three phase pumps available.
- ✓ High level alarm included.
- ✓ Pump stations are delivered complete with the pipework and valves pre-assembled in the tank, ready for immediate installation into the ground.
- ✓ Low maintenance costs, servicing once a year.
- ✓ Custom made units available upon request.
- ✓ Servicing, Installation and Commissioning service available by our highly trained engineers.

## Dimensions (mm)

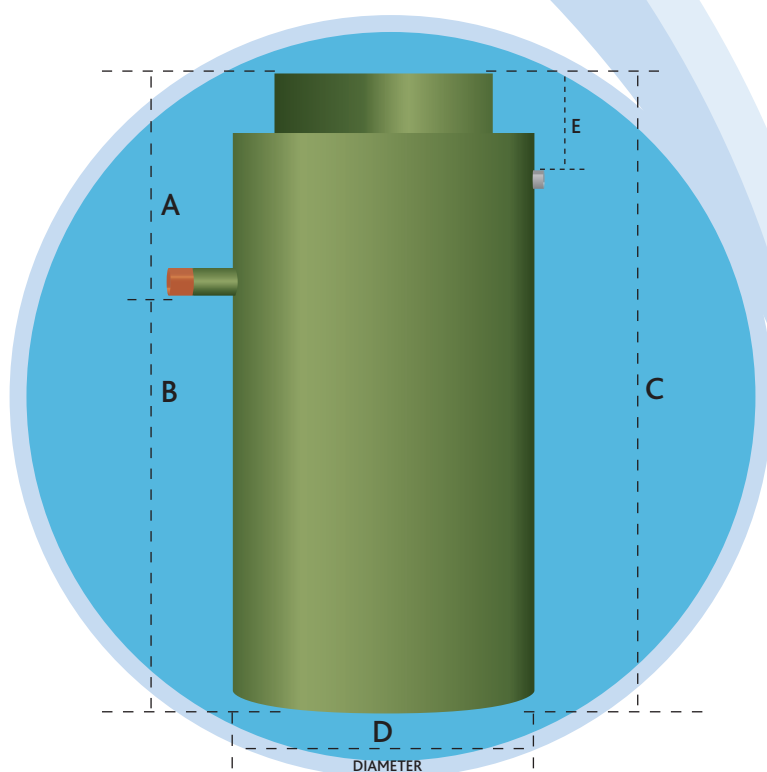

STORAGE CAPACITY / P/E	0	0	0	5	5	5
(A) INLET	500	1000	1500	500	1000	1500
(B) BELOW INLET	900	900	900	1400	1400	1400
(C) HEIGHT	1400	1900	2400	1900	2400	2900
(D) DIAMETER	600	600	600	1000	1000	1000
(E) OUTLET	350	350	350	350	350	350

Allerton® reserves the right to alter the specifications and dimensions without notice.

**1 YEAR WARRANTY ON ALL WORKING PARTS**

**FOR FURTHER INFORMATION  
CALL: 01529 305757  
EMAIL: [sales@allertonuk.com](mailto:sales@allertonuk.com)**