

# Polydilution

A range of polyelectrolyte preparation and dosing units, manual and fully automatic for both powder based and emulsion based polymer.



# Polydilution



## How it works

This range of polyelectrolyte preparation and dosing equipment has been designed for use with our range of sludge dewatering equipment. There are manual (semi-automatic) and automatic versions available.

The manual range is suitable for small plants where the requirement for flocculant is not continuous and personnel are available for chemical make-up. The automatic units are suitable for applications where the polyelectrolyte must be fed on a continuous basis with accurate control of dilution and ageing.

Polyelectrolyte is mixed with a controlled volume of water and enters the dilution tank where it is mixed using a 45° three bladed mechanical stirrer. It then passes to the dispersion tank where it is further mixed before passing into the ageing and storage tank.

Polyelectrolyte solution is withdrawn from this tank by dosing pump (optional). The concentration of the solution can be controlled by adjusting either the water flow rate or the polyelectrolyte input rate.

## Features & Benefits

- ✓ Manual and automatic powder fed units, automatic emulsion fed unit.
- ✓ All metallic parts manufactured from AISI304 Stainless steel.
- ✓ Patented design with CE marking.
- ✓ Capacity up to 60 litres per hour.
- ✓ Controlled mixing to limit polyelectrolyte consumption.
- ✓ Commissioning, servicing and maintenance service available. Installation also available.

## Dimensions (mm)

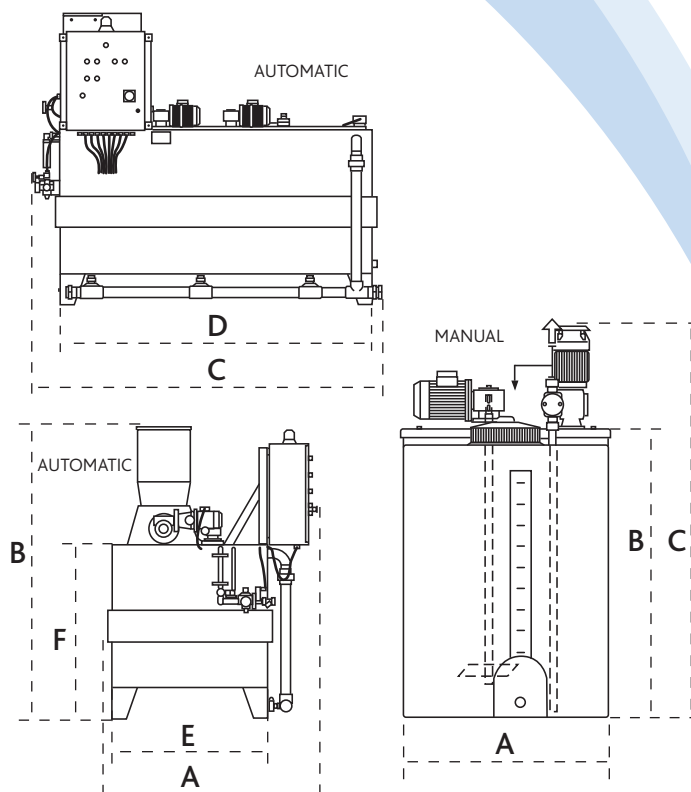

UNIT	MANUAL			AUTOMATIC			
	MINI 300	MIDI 500	MAXI 1000	MINI 750	MIDI 1500	MAXI 3000	MAXI+ 6000
(A)	680	780	1110	1150	1350	1850	2200
(B)	970	1100	1240	1910	1910	2210	2210
(C)	1310	1440	1580	1750	2230	2730	3870
(D)	3/4"	3/4"	3/4"	1400	2000	2500	3500
(E)	-	-	-	800	1000	1500	2000
(F)	-	-	-	1125	1125	1225	1225

Allerton\* reserves the right to alter the specifications and dimensions without notice.

2 YEAR WARRANTY ON  
ALL WORKING PARTS

FOR FURTHER INFORMATION  
CALL: 01529 305757  
EMAIL: sales@allertonuk.com