

# Dual Raw Sewage Pump Station

A high quality Glass Reinforced Plastic tank complete with dual solids handling pumps and built in high level alarm, ideal for single dwellings and small businesses.

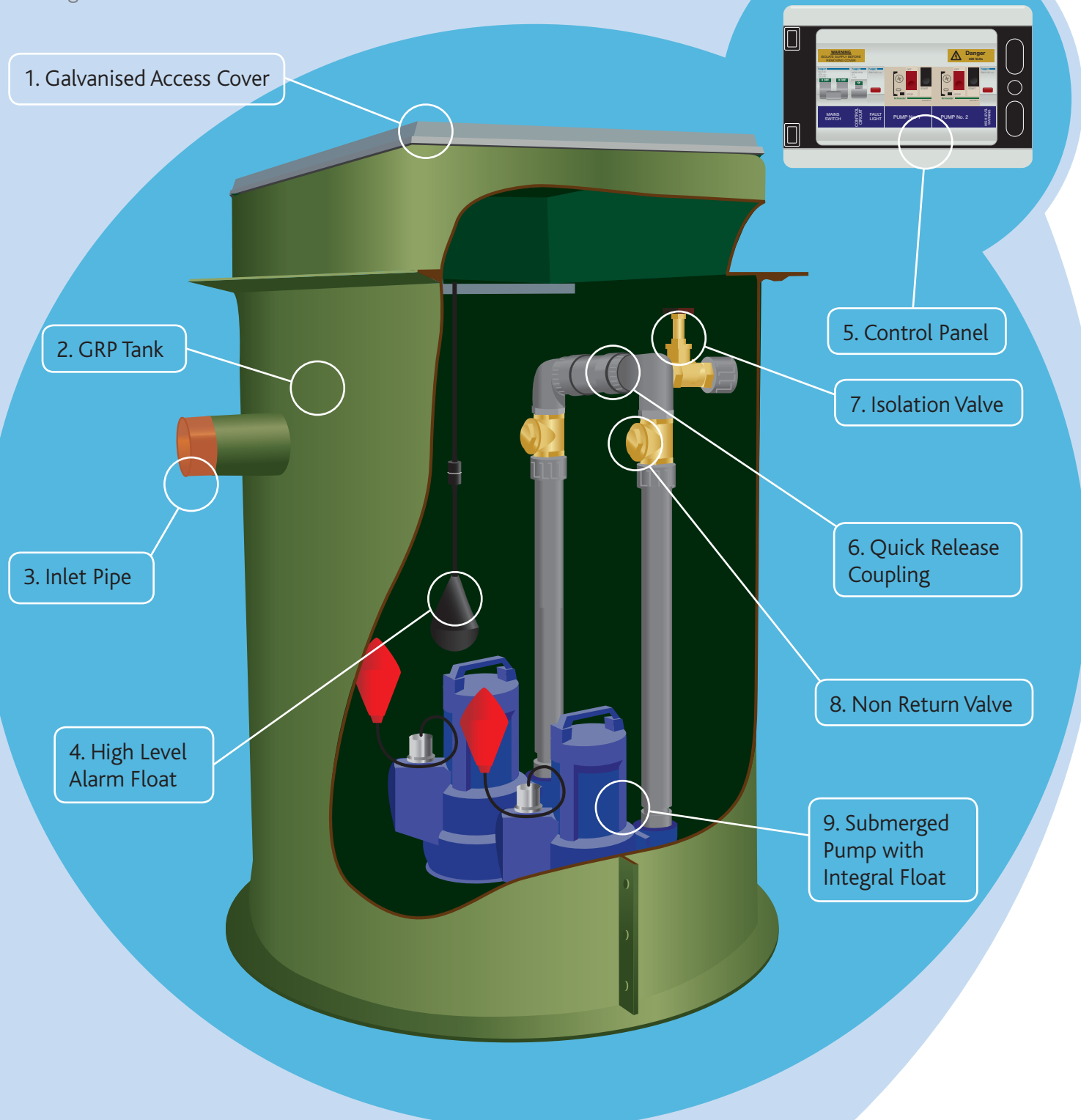

# Dual Raw Sewage Pump Station



## How it works

As the level of the liquid rises in the chamber the integral floats on the pumps are activated and, as the floats are factory set at the same level, both pumps start and pump the liquid out of the chamber until the pump floats drop and the pumps turn off.

The level of the liquid will again rise and the above sequence is repeated. As both pumps are activated each time this ensures equal wear to both pumps.

If both pumps fail to pump, the liquid level will rise to activate the high level float and the high level alarm light will be illuminated.

## Features & Benefits

- ✓ Pump chambers are manufactured from high quality Glass Reinforced Plastic and in accordance with our BS EN ISO9001:2000 quality management system.
- ✓ Single phase and three phase pumps available.
- ✓ High level alarm included.
- ✓ Pump stations are delivered complete with the pipework and valves and pre-assembled in the tank, ready for immediate installation into the ground.
- ✓ Wide range of diameters and depths of tanks available to satisfy the storage requirements in part H of the Building Regs.
- ✓ Low maintenance costs, servicing once a year.
- ✓ Custom made units available upon request.
- ✓ Servicing, Installation and Commissioning service available by our highly trained engineers.

## Dimensions (mm)

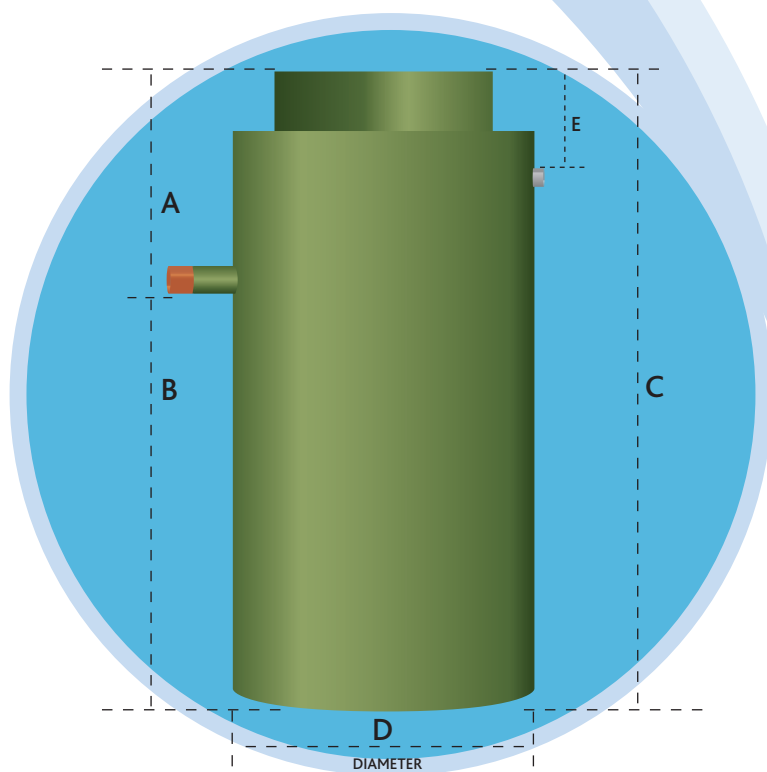

STORAGE CAPACITY / P/E	0	5	12	20	27	44
(A) INLET	500	1000	1000	500	1000	500
(B) BELOW INLET	900	1400	2000	3000	2000	3000
(C) HEIGHT	1400	2400	3000	3500	3000	3500
(D) DIAMETER	1000	1000	1200	1200	1800	1800
(E) OUTLET	350	350	350	350	350	350

Allerton® reserves the right to alter the specifications and dimensions without notice.

**1 YEAR WARRANTY ON  
ALL WORKING PARTS**

**FOR FURTHER INFORMATION  
CALL: 01529 305757  
EMAIL: [sales@allertonuk.com](mailto:sales@allertonuk.com)**